

Dolium® 12,5L D Slim Line

PRODUCT NUMBER : 10-12,5D-21

Characteristics

KEG

Cycle	single use
Volume	12,5L
Dimensions	D x H = 243 x 428 mm
Weight (empty)	1,20 kg
Temperature	0°C < T < 35°C
Pre- pressure	1,0 bar CO2
Working pressure	3,5 bar max.
Pressure Relief Valve	5,2 bar +/- 0,2 bar

CONTAINER

Oxygen ingress	Active barrier
Carbondioxide	Passive barrier
UV ingress	UV light barrier

CONNECTION

Type	D(raft) type = American Sankey-type
------	-------------------------------------

CHIMES

Handling	vertical and horizontal
Storage	stackable

APPLICATIONS

Products	Beverages
Shelf life	Equal to stainless steel
Certificates	EU / FDA
Filling line	compatible - check recommended
Draught installation	compatible
Recycable	100%

for further detailed information please see Handling & Safety instructions

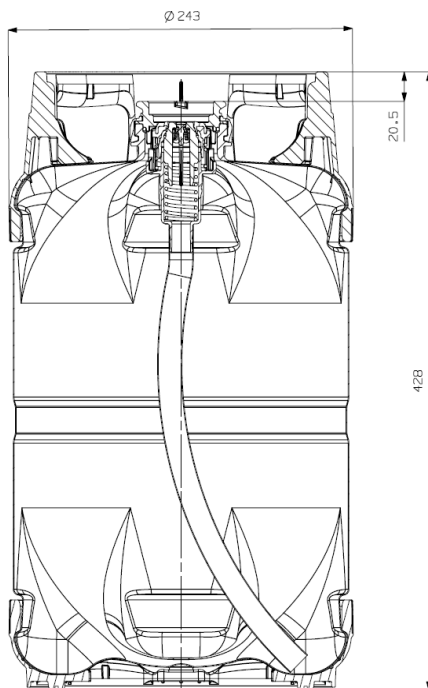
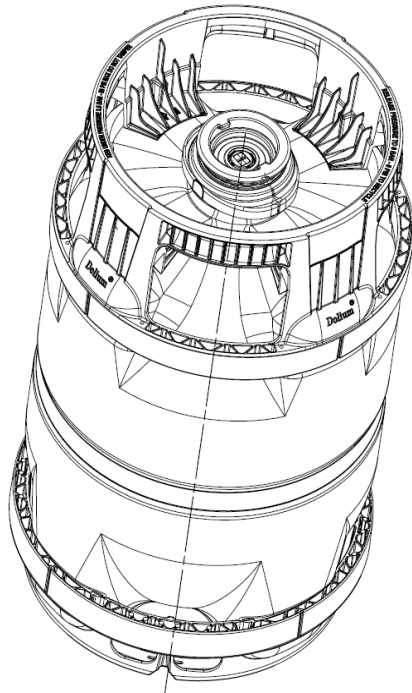

Special features

Contact

Dispack-projects NV

Address: Vosseschijnstraat 192A
 Town: 2030, Antwerpen
 Country: Belgium

E-mail: sales@dolium.eu
 Website: www.dolium.eu